

## Installation Instructions and Information Manual

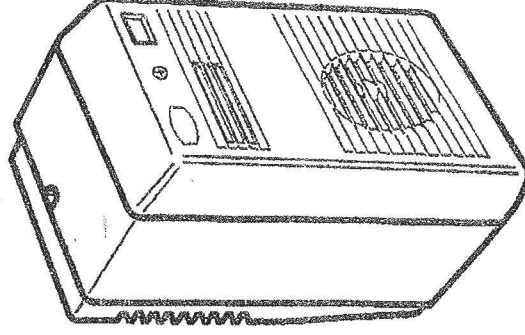

# HEAT RECOVERY FAN HRF

**WARNING:**  
Failure to comply with installation instructions and cautionary notes may invalidate warranty.

**MAINS VOLTAGE**  
Fan 230-240v AC ~ 50Hz  
15w to 40w - Model dependent  
Standard Pull Cord - IP24  
Humidity - IP21

**LOW VOLTAGE**  
Fan 12v AC ~ 50Hz  
15w to 40w - Model dependent

**Transformer**  
Input 230-240v AC ~ 50Hz  
Output 12v AC ~ 42VA  
LV Timer - IP24  
LV Humidity - IP21  
Transformers - IP44

This product is double insulated



ISSUE 2  
01/08 LAB780R

Manufactured in the UK by

## HEAT RECOVERY FAN

The ENERGEX will provide energy efficient ventilation in toilets, bath and shower rooms. It may also be used to reduce humidity and ventilate other rooms such as bedrooms, living rooms, offices and hallways etc. The ENERGEX is supplied with an optional air filter to reduce the amount of soot, dust and pollen entering the room.

The ENERGEX heat exchange fan requires a fitting kit to complete the installation. Pull-cord models should not be installed in ceilings. Models with pull-cord override option should have the pull-cord removed (cut off) before installing in ceilings.

## HEAT RECOVERY FAN RANGE

### SINGLE SPEED

**ENX 100** Fan unit operates whilst switch live is supplied to unit. Designed to be used with remote switch (not supplied). Fan unit incorporates thermo-actuator operated air inlet and outlet shutters.

**ENX 100P** Fan unit operates whilst switch live is supplied to unit. Operated by the integral pull cord. Fan unit incorporates thermo-actuator operated air inlet and outlet shutters.

**ENX 100T** Fan unit operates whilst switch live is supplied to unit. When the switch live is turned off the fan continues to work for a period between 45 seconds and 30 minutes (depending on the overrun timer setting). Fan unit incorporates thermo-actuator operated air inlet and outlet shutters.

**ENX 100HTP** Fan unit operates whilst switch live is supplied to unit. When the switch live is turned off, the fan continues to work for a period between 45 seconds and 30 minutes. The fan can also be operated by the integral pull cord which enables the fan to run for the time period set on the timer adjustment. If the fan is off, the fan can also be switched on by the integral humidity sensor. Fan unit incorporates thermo-actuator operated air inlet and outlet shutters.

### TWIN SPEED

**ENX 1002SC** Fan unit is designed to operate with a remote switch. The fan will run continuously at lower speed and will switch to higher speed when the remote switch is turned on. Fan unit does not incorporate thermo-actuator operated air inlet and outlet shutters.

**ENX 1002SP** Fan unit is designed to be operated by the integral pull cord. When the pull cord is operated from the OFF position, the fan will run at lower speed. When the pull cord is operated again, the fan will operate at the boost speed. When the pull cord is pulled again, the fan switches off (Off-Low-Boost-Off). Fan unit incorporates thermo-actuator operated air inlet and outlet shutters.

**ENX 1002SPC** Fan unit is designed to operate with the integral pull cord. The fan will run continuously at lower speed and will switch to higher speed when the pull cord is operated. When the pull cord is operated again, the fan returns to the slower speed (Low). Fan unit does not incorporate thermo-actuator operated air inlet and outlet shutters.

**ENX 1002SHTP** Fan unit operates at high speed whilst switch live is supplied to the unit. When the switch live is turned off, the fan continues to work for a period between 1 and 30 minutes. The fan can also be operated by the integral pull cord which enables the fan to run at high speed for the time period set on the timer. If the fan is off, the fan can also be switched on to the lower speed by the integral humidity sensor. Fan unit incorporates thermo-actuator operated air inlet and outlet shutters.

**ENX 1002SHB** Fan unit runs continuously at low speed and will switch to higher speed when the integral humidity sensor detects a significant increase in the level of humidity. The unit is fitted with a switch live and pull cord so that boost may be operated independently from the humidity controls when required. Fan unit does not incorporate thermo-actuator operated air inlet and outlet shutters.

### SELV MODELS

**ENX 100LV** Fan unit operates whilst switch live is supplied to transformer and the 12V ac output of the transformer is connected to the fan. Designed to be used with remote switch (not supplied). Fan unit does not incorporate thermo-actuator operated air inlet and outlet shutters.

**ENX 100LVT** Fan unit operates whilst switch live is supplied to transformer and 12V ac output of the transformer is connected to the fan. When the switch live is turned off, the fan continues to work for a period of between 1 minute and 30 minutes. Fan unit does not incorporate thermo-actuator operated air inlet and outlet shutters.

**ENX 100LVHT** Fan unit operates whilst switch live is supplied to transformer and the 12V ac output of the transformer is connected to the fan. When the switch live is turned off, the fan continues to work for a period between 1 minute and 30 minutes. The fan can also be operated by the integral pull cord which enables the fan to run for the time period set on the timer adjustment. If the fan is off, the fan can also be switched on by the integral humidity sensor. Fan unit does not incorporate thermo-actuator operated air inlet and outlet shutters.

## CLEANING

Cleaning and Maintenance of the ENERGEX should be carried out by a qualified electrician.

It is recommended that the ENERGEX fan unit be dusted out and the filter and heat exchanger washed at 6 monthly intervals. To do this remove the front cover as previously described. The filter and heat exchanger can now be removed. The dust can be removed from the fan unit with a soft dry brush or vacuum cleaner.

The front cover can be washed in warm water and dishwashing liquid.

The outside of the fan body can be cleaned with a damp cloth.

The air filter should be washed in warm water with dishwashing liquid.

When clean squeeze out any excess water BUT DO NOT WRING DRY, then lay out on a flat surface to dry.

The heat exchanger should be rinsed under a cold tap and shaken to remove any surplus water. When all components are clean and dry, reassemble the fan in reverse order.

It is recommended that every two years the fan chassis is removed from the mounting box to enable the air filter to be cleaned.

With the fan chassis face down on a flat surface, remove the three screws retaining the back plate. Place the backplate to one side and dust the air inlet around the motor with a soft brush or vacuum cleaner.

When the air inlet is clean, replace the backplate making sure that no wires are trapped.

**NOTE:** Do not put any components in a dishwasher.

**WARNING: ISOLATE ELECTRICITY SUPPLY BEFORE COMMENCING WORK**

## ADJUSTING SENSOR AND TIMER SETTINGS FOR 230-240V MODELS

To adjust sensor or timer settings the front cover must be removed as previously described. All controls are clearly marked.

### TIMER

Turn anti-clockwise for less overrun time and clockwise for more overrun time. The timer is adjustable between 30 seconds and 25 minutes approx.

### HUMIDITY

Turn anti-clockwise for less sensitivity and clockwise for greater sensitivity. The range of adjustment is between 50° RH and 90° RH approx.

### ADVICE CONCERNING HUMIDITY CONTROLS

Condensation/humidity controls are designed to switch an extractor fan on when the room humidity exceeds a pre-set level. In order to achieve this the humid air must invade the sensor housing. This process can take some time and when the room is in use this delay may cause some concern. Also the sensor cannot detect smells or smoke and we therefore recommend that fans with humidity controls should be wired up with manual (switch live) operation where applicable.

### CAUTION

Fans incorporating electronic control systems may be damaged if used in conjunction with fluorescent lamps.

## ASSEMBLY AND FITTING OF THE HEAT RECOVERY FAN

The ENERGEX is packaged fully assembled. In order to install the fan it must be stripped to its four main components:

- 1 Front Cover
- 2 Heat Exchanger
- 3 Main Fan Chassis
- 4 Mounting housing

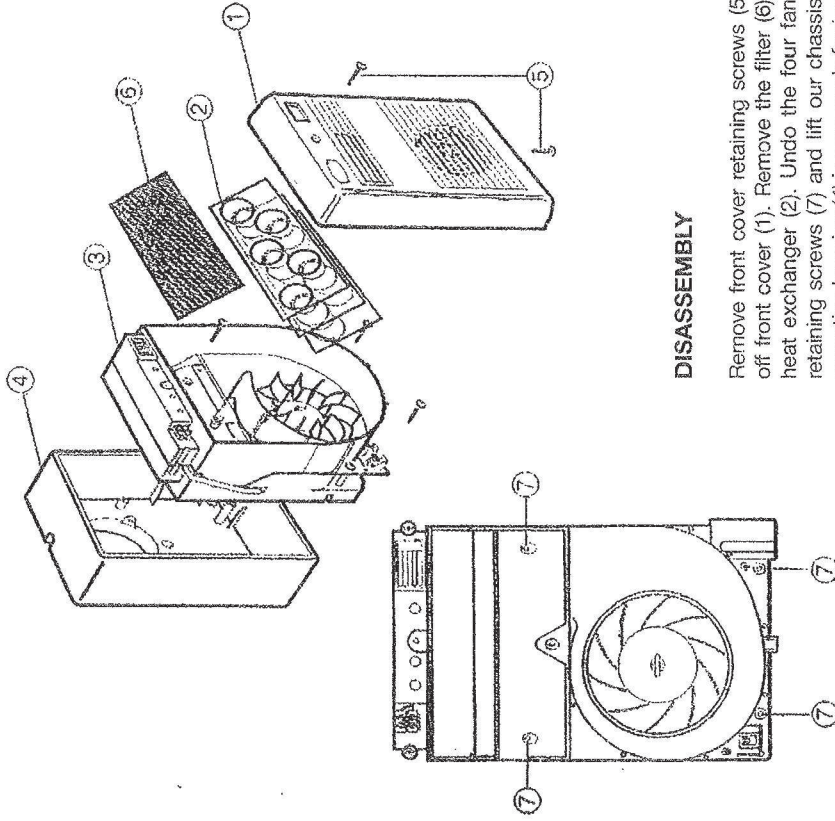

### DISASSEMBLY

Remove front cover retaining screws (5) and lift off front cover (1). Remove the filter (2) and the heat exchanger (3). Undo the four fan chassis retaining screws (7) and lift out chassis (3). The mounting housing (4) is now ready for installation.

### REASSEMBLY

Reassemble the fan in reverse order. When reassembling the fan it is important that the heat exchanger is positioned as indicated above and that the screws are not overtightened.

## WALL FITTING

When duct is in position wiring provision should be made as required. The duct divider and discharge grille should be fitted as described below. After the duct divider and discharge grille have been fitted the housing can be fixed into position using the screws and plugs provided. For surface mounting the trim bezel provided may be discarded. The fan chassis can now be fitted and wiring connections made (refer to wiring diagrams). Fit heat exchanger filter and front cover.

### FLUSH MOUNTING - Fig 2.

Cut a hole through the wall allowing for condensation drainage as described previously. Place mounting housing on inside wall and mark for cutting. Cut away sufficient depth to permit the housing to be let into the wall to the desired depth.

**Note:** The front edge of the housing must be at least 15mm proud of the wall surface to permit the trim bezel to be fitted. Fit the required cabling and make the housing secure. Holes can be made in the mounting housing for fixings if required.

Insert the ducting from the outside having first cut it so it is flush with the wall surface and grout it into place. Make good the housing surrounding and fit the trim bezel.

connections made (refer to wiring diagrams). Fit heat exchanger filter and front cover.

### FITTING THE DUCT DIVIDER.

The duct divider is essential as it divides the 100mm duct into two. This allows for a two way air-flow required by the fan unit. The divider is supplied with the fan end pre-prepared. The end must be prepared as follows :

Cut the divider to the same length as the duct.

Cut the soft side tubes as detailed in fig. 5. Wet the side tubes to the divider and insert it horizontally into the duct.

### FITTING THE FAN CHASSIS.

Fit the fan chassis into position making sure the divider is in position in the back of the fan discharge baffle. Connect wiring as necessary. Refer to wiring diagram. Fit heat exchanger, filter and front cover.

### WARNING :

To prevent combustion gases entering the air inlet, the HRF unit must not be positioned above or within 600mm of a flue vent.

**WARNING: ISOLATE ELECTRICITY SUPPLY BEFORE COMMENCING WORK**

## ENERGEX LOW VOLTAGE

### INSTALLATION INFORMATION

#### POSITIONING THE FAN UNIT.

The fan may be installed in window, wall or ceiling. If fitted on a wall it should be as high as possible. If fitting in a shower cubicle or over a bath with a shower, the fan should be positioned above the shower head. The LV humidity model must be positioned in a splash free area as the humidity sensor will be damaged if in direct contact with water.

#### POSITIONING THE TRANSFORMER.

The transformer must not be positioned less than 1.5 metres from a bath or shower. The wiring length between the fan unit and the transformer should be kept to a minimum and not exceed 8 metres. The transformer should be positioned high on the wall or on the ceiling if in the same room as the fan unit. It is normal for the transformer to get warm when operating, therefore it is important that air is allowed to circulate around it. The transformer should not be installed in small enclosed spaces. Access must be allowed for servicing and timer adjustment. If installing the transformer in a roof space it must not be covered with insulation material.

#### TRANSFORMER FITTING INSTRUCTIONS.

1. Remove front cover retaining screw.
2. If using rear entry cabling remove knock-outs.
3. If using surface cabling cut suitable hole in sealing grommets.
4. Using the transformer as a template mark fixing hold and cable entry positions.
5. Once cabling and resurfacing is complete drill and plug fixing holes.
6. Fit the transformer into position and make power connections as detailed. Refit front cover.

**IF IN DOUBT, CONSULT A QUALIFIED ELECTRICIAN**

**WARNING: ISOLATE ELECTRICITY SUPPLY BEFORE COMMENCING WORK**

## MODEL STANDARD WITH EXAMPLE 2 SPEED SWITCH

### Twin speed switch terminal

-  Earth termination
- N In Mains Neutral
- N Out Fan Neutral
- L In Mains Live
- L1 Live to Fan (Slow)
- L2 Live to Fan (Fast)

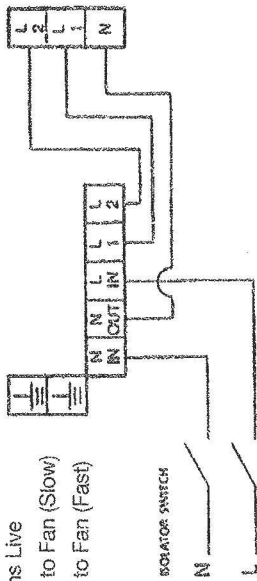

Note: Pull cord model cannot be installed in ceilings.

Note: Humidity Model features a useful pull-cord override. This is operated via the built in pull-cord switch. When used the fan will operate for the time set into its integral timer, then turn itself off. The fan cannot be turned off using this switch. The short run facility is not intended to be used as the main operating switch. When fitting in ceilings this feature cannot be used. We recommend that the pull-cord is cut off before installation.

## CEILING FITTING WITH CEILING KIT

### Fitting Kit Contents:

- 1 x Ceiling Ducting Adaptor
- 1 x Trim Bezel
- 1 x Pack x 2 screws

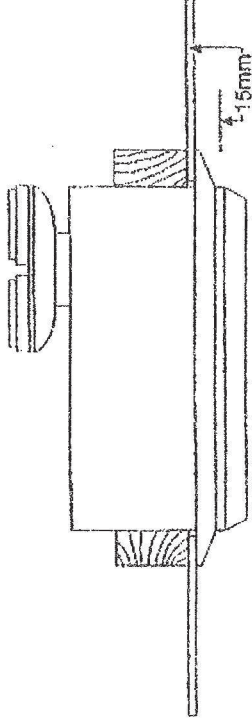

### FITTING

Disassemble the fan to its main components as described on page 3. Using the mounting housing mark desired position on ceiling avoiding joists above. The fresh air inlet grille (the oblong one) should be directed towards the wall to avoid any discomfort from draughts.

Cut the hole to take the mounting housing. Two battens should be fitted along the sides of the hole to screw the mounting housing to. Drill at least two holes on the sides of the mounting housing adjacent to the battens. Fix the mounting housing into position using screws provided.

### NOTE:

The front edge of the mounting housing **must** be at least 15mm proud of the ceiling surface. Now fit the trim bezel into position.

### DUCTING

From above the ceiling fit the ducting adaptor into position over the fan spigot. The adaptor must be positioned lengthways so that the divider slots into the slot in the discharge baffle. To make sure of correct alignment fit the fan chassis into position. Secure adaptor with duct tape. Do not use adhesive.

The discharge ducting may exit the building via the eaves, gable end, ridge tile or roof cowl. In all cases the ducting should have provision for condensation drainage. On horizontal ducting this can be provided by leaving a low point in the duct run and on vertical ducting drainage can be provided by using a condensation trap. It is good practice to use rigid duct wherever possible and keep the duct runs as short as possible. The discharge duct should be insulated to keep condensation to a minimum. The inlet ducting may be installed the same way as the discharge ducting or terminated in the loft.

## CEILING FITTING

The inlet should have a grille fitted or ideally an inlet filter. This will prevent most dust and pollen particles entering the room. Remove the fan chassis if fitted and install cabling, refit fan chassis and make wiring connections as required. Fit the heat exchanger, filter and front cover.

The fan unit can also be surface mounted if required. If taking this option battens should be fitted between joists to take the weight of the fan. For surface mounting the trim bezel can be discarded.

## FITTING AN ENERGEX IN PLACE OF AN EXISTING EXTRACT FAN

The installation of ordinary 100mm extract fans is similar to the HRF.

The duct divider will fit most standard 100mm ducts because of the soft deformable tubes on the edges. In ceiling fitting the ducting must be installed for the inlet air and ducting adaptor to be used. The HRF can replace centrifugal window fans using 120mm holes. The HRF inlet/discharge spigot is on the centre line of the fan unit so it hangs evenly. Therefore it does not require extra brackets needed by some extract fans.

### WARNING :

To prevent combustion gases entering the air inlet, the HRF unit must not be positioned above or within 600mm of a flue vent.

### WIRING INSTALLATION

#### Wiring requirements for domestic electric fans

The fan should be connected via double pole (5mm) isolation into the lighting circuit. The isolation should be before the room light switch and suitably fused in accordance with I.E.E. Regulations.

Window fans should be connected to power supply using a flexible cord with conductors of between 0.75 and 1.5mm<sup>2</sup> only.

Wall and ceiling mounted fans for fixed wiring should be connected to the power supply via a cable with solid conductors of 1mm<sup>2</sup> to 1.5mm<sup>2</sup> only.

After installation and wiring, it is the installer's responsibility to ensure that any cable access hole used is suitably sealed to maintain the appropriate product protection rating.

Do not fit mains powered fans within a shower cubicle or above a bath. In these circumstances fit a LOW VOLTAGE unit.

IF IN DOUBT, CONSULT A QUALIFIED ELECTRICIAN.

WARNING: ISOLATE ELECTRICITY SUPPLY BEFORE COMMENCING WORK

## ENX 1002SC

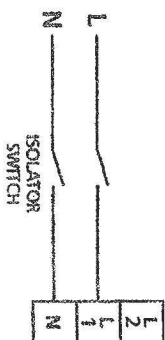

MODEL ENX1002SC with two speed switch. ANC812A

Fan Terminals

- L2 - Live Fast
- L1 - Live Slow
- N - Neutral

### Two speed switch terminal

- Earth termination
- N In Mains Neutral
- N Out Fan Neutral
- L in Mains Live
- L1 Live to Fan (Slow)
- L2 Live to Fan (Fast)

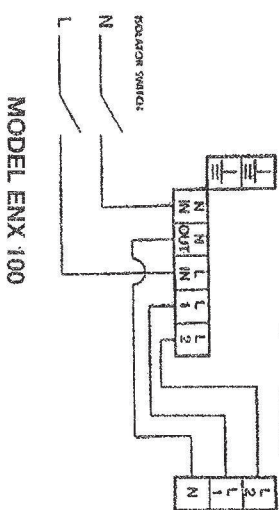

MODEL ENX 100

Fan Terminals

- N - Neutral
- L - Live

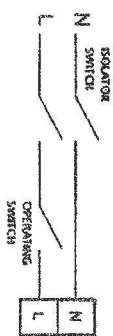

MODELS ENX 100P, ENX1002SCP, ENX 1002SP

Fan Terminals

- N - Neutral
- L - Live

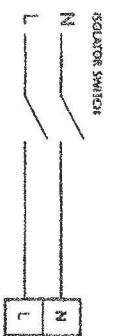

MODELS ENX 100T, ENX 100HTP, ENX 1002SCTP  
ENX 1002SHTP, ENX1002SHTPE

Fan Terminals

- S/L - Switch Live
- N - Neutral
- L - Live

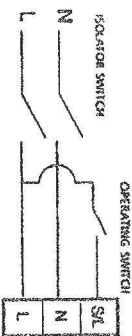

WARNING: ISOLATE ELECTRICITY SUPPLY BEFORE COMMENCING WORK